

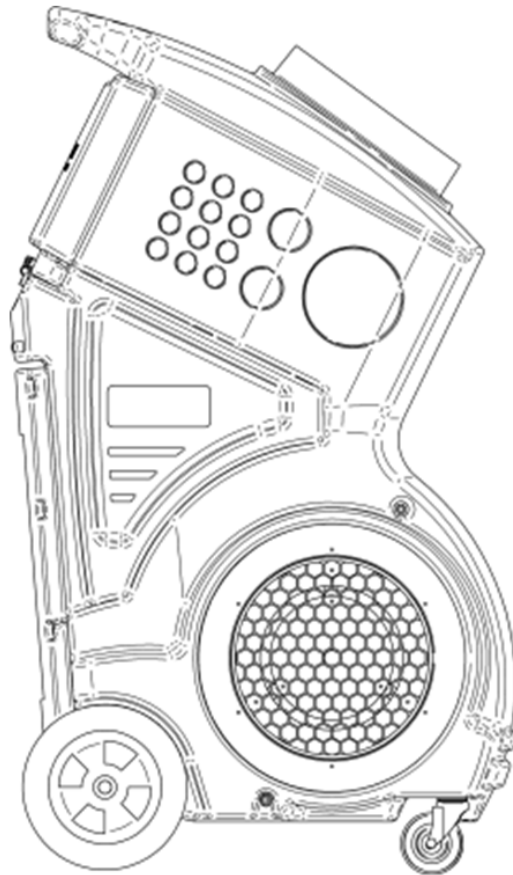

PREDATOR[®] Portable Air Scrubber
PRED1200



Instruction Manual

Design covered by:
U.S. PATENT No. D572,356

Abatement Technologies, Inc.

Abatement Technologies, Inc.
Georgia, USA
800-634-9091

Abatement Technologies Limited
Ontario, Canada
905-871-4720

www.abatement.com

READ AND SAVE THESE INSTRUCTIONS!

Note:

1. **Read and understand all operating instructions before using the Portable Air Scrubber.**
 2. **Save this manual for future reference.**
-
-

This instruction manual provides important information on operation of the Abatement Technologies PREDATOR® Portable Air Scrubber. These instructions must be carefully followed in order to operate the units safely and correctly. If you have any questions regarding the use or care of this equipment call Abatement Technologies at +1 800-634-9091 (U.S.) or +1 905-871-4720 (Canada) for assistance.

Abatement Technologies strongly recommends users of the room air filtration units and accessories to follow the most recent guidelines and/or standards published by the: Occupational Safety and Health Administration, Centers for Disease Control and Prevention, Environmental Protection Agency, American Society of Heating, Refrigerating and Air Conditioning Engineers, and all other federal, state, provincial and local regulations.

TABLE OF CONTENTS

Safety Instructions	1
Requirements For Safe Operation.....	1
Important Safety Instructions.....	1
General Information.....	2
Standard Air Filter Stages (Supplied With the Unit).....	2
Optional Third Stage Filter (Purchased Separately)	3
Determining the Required Number of Air Filtration Devices (AFD)	3
Electrical Requirements	4
Key Components.....	4
Key Component Descriptions.....	5
Operating the Unit	5
Before Operating the Unit	5
Modes of Operation	5
Control Panel	6
Daisy Chaining.....	6
Starting the Unit	7
Transporting the Unit.....	7
Foam Inlet Plug.....	7
User Servicing Instructions	7
Filter Replacement.....	7
Filter Change Indicator	8
Filter Change Procedure.....	8
Component Replacement and Care of the Unit.....	9
PRED1200 Specifications.....	10
Troubleshooting Guide.....	11
Certification of Room Air Filtration Units.....	12
Limited Warranty.....	12
HEPA Certification	12
PRED1200 Diagrams	13

SAFETY INSTRUCTIONS

REQUIREMENTS FOR SAFE OPERATION

1. Never allow unauthorized individuals or children to operate the unit at any time.
2. Abatement Technologies urges anyone operating PREDATOR® scrubber units to wear the proper personal protective equipment and follow safe work practices in accordance with federal, state, local, provincial and employer regulations.
3. Check the condition of power cord(s) before using them. Damaged cords can cause fatal electric shock and/or motorized impeller failure.
4. Power cord(s) should never be exposed to water, heat, and/or sharp or abrasive objects. In addition, they should never be kinked or crushed. Avoid tightly wrapping the cords to prevent kinking of the internal wires. Always replace damaged power cords immediately.
5. Never pull the unit by the power cord.
6. Avoid running over power cords with utility equipment and vehicles.

 If the equipment is used in a manner not specified by the manufacturer, the protection provided by the equipment may be impaired.

IMPORTANT SAFETY INSTRUCTIONS

- a. Do not operate any unit with a damaged cord or plug. Discard unit or return it to an authorized service facility for examination and/or repair.
- b. Do not run cord under carpeting. Do not cover cord with throw rugs, runners, or similar coverings. Do not route cord under furniture or appliances. Arrange cord away from traffic area and where it will not be tripped over.

 **Caution:** As with any piece of electrical equipment, always make sure that the unit is turned “OFF” prior to connecting the power cord to an electrical outlet or disconnecting it from an electrical outlet. Failure to do so will cause “arcing”, and could result in personal injury, fire hazards and/or damage to the unit. Do not disconnect the power cord from supply receptacle while the unit is operating.

 **Warning:** To reduce risk of electrical shock, do not expose this unit to water or rain. Do not touch the electrical outlet or power cord(s) with wet hands or while standing on a wet or damp surface.

 **Warning:** Risk of electrical shock! Can cause injury or death! Turn unit “OFF” and disconnect power cord from supply receptacle before replacing the HEPA filter and before cleaning or servicing the unit.

 **Warning:** To reduce the risk of fire, electric shock, or injury to person observe the following: Use this unit only in the manner intended by Abatement Technologies. If you have questions, contact Abatement Technologies at +1 800-634-9091 (U.S.) or +1 905-871-4720 (Canada).

 **Warning:** This unit is equipped with an automatic restart motorized impeller that will restart without warning after a temporary power interruption or recovery from a thermal overload (over-heating) condition. Keep clear of the motorized impeller at all times to reduce the risk of injury.

 **Warning:** To reduce risk of fire or electrical shock, do not use this unit with any solid-state speed control device. Do not use in a cooking area.

 **Warning:** Do not position the unit so that it is difficult to operate the disconnecting device. The disconnecting device is the power cord plug.

⚠ Caution: This unit is designed for indoor use only.

⚠ Caution: For General Ventilating Use Only. Do Not Use To Exhaust Hazardous Or Explosive Materials And Vapors.

⚠ Warning: Do not connect the unit's power cord to a supply receptacle unless the inlet and power modules are in their proper position and latched together.

⚠ Warning: Abatement Technologies air filtration systems are not intrinsically safe for use in hazardous environments. Always consult a certified industrial hygienist before using them. Do NOT use this equipment in any atmosphere that is or may be immediately dangerous to life or health (IDLH), combustible, flammable, explosive, oxygen deficient, and/or contains odors, vapors, gases or particulates that exceed permissible exposure levels. Such atmospheres may require the use of intrinsically safe equipment, specific engineering controls, and personal protective equipment in accordance with Occupational Safety and Health Administration (OSHA), Environmental Protection Agency (EPA), Canadian Standards Association (CSA), and other federal, state, provincial and local regulations.

⚠ Warning: This equipment is not classified as "intrinsically safe" and should not be used in the following hazardous locations as defined by the Underwriters Laboratories: Class I Division 1, Class I Division 2, Class I Zone 0, Class I Zone 1, Class I Zone 2, Class II Division 1, Class II Division 2, Class III Division 1, Class III Division 2. Refer to http://en.wikipedia.org/wiki/Electrical_equipment_in_hazardous_areas.

⚠ Warning: Do not use this unit near sparks, open flames or other possible sources of ignition.

GENERAL INFORMATION

The PRED1200 Portable Air Scrubbers are multi-use air filtration devices, equipped with pre-filters and a HEPA filter that are capable of filtering many airborne contaminants. An alternate carbon pre-filter for capturing low concentrations of odors, vapors, gases, and volatile organic compounds, collectively known as OVG, is also available.

Types of contaminants captured by particulate pre-filters, HEPA filter, or carbon filters:

- Dirt
- Dust
- Drywall dust
- Saw dust
- Lung-damaging particles
- Metal fumes
- Smoke
- Mold and fungal spores
- Low concentrations of OVG
- Low concentrations of Volatile Organic Compounds (VOC)
- Unpleasant nuisance odors

Note: To capture low concentrations of OVG, a VAPOR-LOCK® carbon filter must be used.

The PRED1200 Portable Air Scrubbers are capable of providing particulate and odor, vapor, gas filtration with final stage filtration through a High Efficiency Particulate Air (HEPA) filter. These units incorporate a series of particulate filters that successively remove larger size to smaller size particles from the air. In addition to providing HEPA filtration, the PRED1200 units are primarily used in a negative pressure or recirculation mode. A negative pressure condition is created in order to confine contaminated airborne particles. This condition exists when the static pressure inside the room containing the unit is lower relative to the pressure of the environment outside the room. The static pressure differential is created and maintained by continuously exhausting air out of a given room at a faster rate than air enters the room from all other sources. In the recirculation mode, all of the filtered air is exhausted back into the room containing the unit.

STANDARD AIR FILTER STAGES (SUPPLIED WITH THE UNIT)

The PRED1200 units come equipped with two progressively efficient pre-filters mounted in the pre-filter compartment, and a final stage HEPA filter, located inside the cabinet:

- First stage, 1" deep, coarse particulate pre-filter (P/N: F621) is designed to capture particles 100 microns or larger.
- Second stage. 2" deep, particulate pleated pre-filter (P/N: H502) is designed to capture particles 10 microns or larger.
- Final stage. HEPA filter (P/N: H610C-99) is tested & certified to capture at least 99.97% (9,997 out of 10,000) 0.3-micron particles.

Note: The particulate filters included with this unit do not remove odors, vapors or gases, including volatile organic compounds.

OPTIONAL THIRD STAGE FILTER (PURCHASED SEPARATELY)

VAPOR-LOCK® pleated, high-capacity, carbon filters (P/N: VL1002) are available for capturing OVG. These 2"-deep filters can be used as an alternate second stage pre-filter to reduce airborne OVG by chemically bonding the OVG molecules to the surface area of the carbon granules via a process known as adsorption. The VL1002 filters also provides a similar level of particulate filtration efficiency to the H502 pre-filters.

Effective carbon adsorption is dependent upon the amount of carbon & exposed carbon granule surfaces, and the dwell (contact) time the OVG molecules have with the carbon granules. Operating the unit at lower speed settings to increase dwell time can therefore improve OVG adsorption, though it is highly unlikely that all of the OVG will be removed in one pass of air through the unit. Operating the unit in the recirculation mode can increase effectiveness, by exposing OVG particles to multiple passes through the VAPOR-LOCK® filter.

It is almost impossible to provide accurate estimates to two commonly asked questions: "how much time will it take to capture all of the OVG?", and "how do I know when a carbon filter should be replaced?" Unfortunately, unknown factors – such as concentration levels, fresh-air intake volume, temperature, and humidity – prevent establishment of any more accurate 'rule of thumb' than one's sense of smell. Since off-gassing of adsorbed OVG can occur when the adsorption capacity of the filter is reached, replace the carbon filter as soon as odor breakthrough is sensed. More detailed information on carbon adsorption can be found in an article titled: "Activated Carbon: How Is It Used? How Does It Work?" which can be found on the Abatement Technologies website, www.abatement.com.

DETERMINING THE REQUIRED NUMBER OF AIR FILTRATION DEVICES (AFD)

1. Calculate the total air volume (V) in cubic feet (ft³) within the enclosed containment area by multiplying the length (L) x the width (W) x the height (H), all in feet ($V = L \times W \times H$).
2. Determine the minimum number of air changes per hour (ACH) specification. When no ACH number is specified, most users target at least 6 ACH for construction areas. A good practice is to build in a safety factor to compensate for filter loading, duct losses, reduced voltage, and other factors that can reduce actual installed airflow. For example, if 6 ACH is the objective, enter 7.5 ACH for a 25% safety factor, enter 9 ACH for a 50% safety factor, or enter 10.5 for a 75% safety factor.
3. Select an Abatement Technologies room air filtration device (AFD) model and determine the peak airflow rating for that model in cubic feet per minute (CFM).
4. Determine the total number of AFD required using the following formula: $\text{Quantity} = (V \times \text{Design ACH}) / (\text{AFD Rating} \times 60)$
5. Always round up to the next whole number. For example, if the total number of AFD required is 1.32, 2 units are recommended, not 1.

Example: How many air filtration devices (each with 900 CFM rated airflow) would be required to provide 7.5 ACH (including a safety factor) in a 20' x 36' x 12' containment area?

1. $V = 20 \text{ ft} \times 36 \text{ ft} \times 12 \text{ ft} = 8640 \text{ ft}^3$
2. Design ACH = 7.5
3. Quantity of AFD required = $(8640 \text{ ft}^3 \times 7.5 \text{ ACH}) / (900 \text{ CFM} \times 60) = 64800/54000 = 1.2 \text{ units}$
4. 1.2 units → 2 units required.

ELECTRICAL REQUIREMENTS

1. The PRED1200s require a minimum of 110 volts AC, 60 Hz to operate properly; however, maximum air flow performance requires 120 volts AC, 60 Hz.
2. Due to momentary start-up current surge, the unit requires a 15 amp circuit that is free of other loads.
3. Extension cords used for this unit must be UL-listed, heavy duty No. 14/3 AWG SJTW industrial grade 3-wire type. Use of larger numerical gauge (lower capacity wire) power cord(s) may result in electrical shock, fire hazards and/or damage to unit. The cord(s) must be in good condition and in continuous lengths (no splicing) and should not exceed a total of 50 feet (15 meters) in length. Make certain that any extension cords used do not reduce power to the unit to less than 110 volts. Use of a voltmeter to confirm adequate voltage is recommended.
4. Check to ensure that any circuit to which the unit is connected is protected by a 15 amp circuit breaker. The unit itself is equipped with a 12 amp circuit breaker.
5. The units should be connected to a three-prong, properly grounded electrical outlet equipped with a Ground Fault Circuit Interrupt (GFCI) device. A GFCI is an electrical safety device that will trip the circuit and stop the flow of electricity if leakage of current is detected.
Important Note: The GFCI on the PRED1200 control panel only detects leakage of current from the unit or an electrical device plugged into the GFCI. The PRED1200 should be plugged into a GFCI receptacle at the power source to protect the power cord and the unit. This GFCI will trip the circuit if it detects leakage of current from the power cord or unit.
6. To avoid personal injury, fire hazards and/or damage to the unit's electrical system and power cord, do not connect or disconnect the power cord to an electrical outlet unless the unit is switched to the "OFF" position.

KEY COMPONENTS

Predator Portable Air Scrubber Model: Pred1200

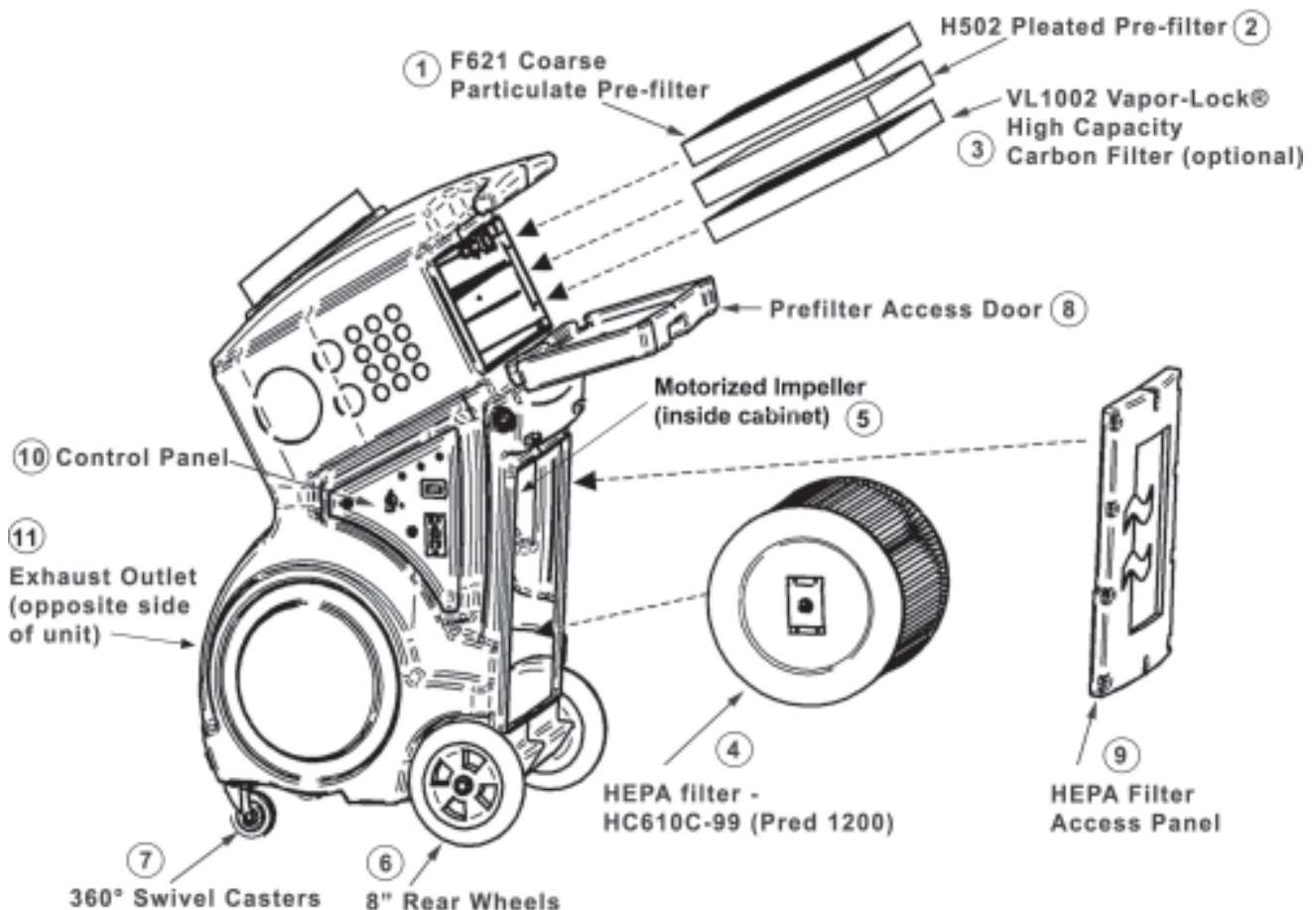

KEY COMPONENT DESCRIPTIONS

1. First Stage Filter. 1" Coarse/Particulate Pre-filter (P/N: F621).
2. Second Stage Filter. 2" Pleated Particulate Pre-filter (P/N: H502).
3. Optional Third Stage Filter. 2" High Capacity Carbon Filter (P/N: VL1002).
4. Final Stage Filter. 99.97% HEPA filter (P/N: H610C-99).
5. Motorized Impeller.
6. 8" Rear Wheels.
7. 360° Swivel Casters.
8. Pre-filter Access Door.
9. HEPA Filter Access Panel.
10. Control Panel.
11. Exhaust Outlet – 10" nominal diameter.

OPERATING THE UNIT

BEFORE OPERATING THE UNIT

Inspect and tighten any HEPA filter retaining bolts that may have loosened during transportation. Inspect the filters for any material or structural damage prior to use and replace any damaged filters before operating the unit. When removing any filters prior to operation, always put them back in place with the airflow indicator on the filter housing oriented in the proper direction (if applicable).

As with any air filtration system, external airflow losses not attributable to the air filtration unit will reduce the airflow of the system. The following recommendations can minimize airflow losses created by external static resistance.

1. Always use the minimum length of ducting possible with the fewest possible number of turns and bends.
2. Rigid metal ducting creates less turbulence and consequently less airflow loss than flexible ducting. Regardless of the type of ducting used, rigid, "sweep-type", radiused connections should be used for all turns and bends.
3. If flexible ducting is used, it must be kept as taut as possible to avoid flattening.

MODES OF OPERATION

1. **Negative Pressure** – used to help ensure that airborne contaminants do not escape from a contained area by maintaining negative (lower) air pressure within that area compared to adjacent areas. Any air leakage will be an inflow of external air, not an outflow of contaminated air. To ensure that the proper pressure differential is maintained, the volume of HEPA-filtered air exhausted from the containment area must be the greater of 10% or 100 CFM higher than the volume of air entering. This pressure differential can be established by:
 - a. placing the unit inside the containment area and using it to push air out of the containment area. Attach flex duct at the outlet collar and exhaust the HEPA-filtered air outside of the containment area according to regulations – outdoors or another location within the building.
 - b. placing the unit outside of containment area and using it to pull air out of the area. Attach flex duct between the inlet collar and the containment area.
2. **Recirculation** – used to reduce concentrations of airborne contaminants in a room or area by continuously cleaning the air and exhausting it back into the same room or area.
3. **Positive Pressure** – used to help prevent airborne contaminants from entering a containment area by maintaining positive (higher) pressure within that area compared to adjacent areas. Any air leakage will be an outflow of clean air, not an inflow of external air. To ensure that the proper pressure differential is maintained, the volume of HEPA-filtered air supplied to the area must be the greater of 10% or 100 CFM higher than the volume of air exhausted. This pressure differential can be established by:
 - a. placing the unit inside the containment area and using it to pull air into the containment area. Attach flex duct between the inlet collar and a location outside of the containment area.
 - b. placing the unit outside of containment area and using it to push HEPA-filtered air into the area. Attach flex duct at the outlet collar and exhaust the HEPA-filtered air inside of the containment area.

If the room air filtration units are being used to create and maintain a negative/positive pressure condition, the pressure differential between the negative/positive room and the environment outside the room should be monitored with a calibrated instrument as per OSHA/CDC requirements. The Abatement Technologies Portable Pressure Monitors are recommended to ensure that requirements are being met.

Important Note: Do not operate the unit unless the pre-filter(s) and HEPA filter are installed and the filter access door and panel are in place and closed.

CONTROL PANEL

1. Speed Control Switch. Serves as the power switch and provides a variable adjustment to the speed of the motorized impeller.
2. Power Indicator. Green light that indicates speed control switch is “ON” and unit is connected to power source.
3. Hour Meter. Provides a count of the total operating hours.
4. Filter Change Indicator – Pre-filter. Amber light that indicates excessive restriction on air intake or loading of the filter(s) and that filter change procedures should be followed.

Note: Check the filter loading indicators when the unit is operating on “HIGH” speed.

5. Filter Change Indicator – HEPA. Amber light that indicates excessive restriction on air exhaust or loading of the HEPA filter and that filter change procedures should be followed.
6. Circuit Breaker. 12 amp circuit breaker that provides protection for the unit’s electrical components.

7. GFCI Receptacle. Electrical safety device that will trip and stop the flow of electricity if leakage of current is detected from the unit or an electrical device plugged into the GFCI receptacle. The PRED1200 plugged into a 120 V/15 A electrical power supply can supply a total of 7 amps of electrical power for additional equipment that is connected to the GFCI receptacle. Do not exceed this 7 amp limit.

Note: If the equipment connected to the GFCI receptacle draws more than a total of 7 amps, the circuit breaker on the control panel and/or the building breaker will trip. This condition can be remedied only by reducing the total amperage draw.

Note: Unit is equipped with a hardwired 25 ft 14/3 AWG SJTW power cord for connection to an electrical outlet.

DAISY CHAINING

“Daisy Chaining” refers to the operation of multiple units on one circuit, with only one of the units plugged into a 120 V/15 A electrical power supply receptacle. Each subsequent unit is plugged into one of the GFCI receptacles on the prior unit, up to the maximum number allowed based on the amperage draw per unit. The National Electrical Code limits the total amperage draw of devices operating on one circuit to 80% of full load, which means that the total amperage draw on a 120 V/15 A circuit, including the unit plugged into the building electrical power supply receptacle, must not exceed 12 amps.

A total of **three** PRED1200 units, including the unit plugged into the building electrical power supply receptacle, can be “Daisy Chained” on a 15 amp circuit.

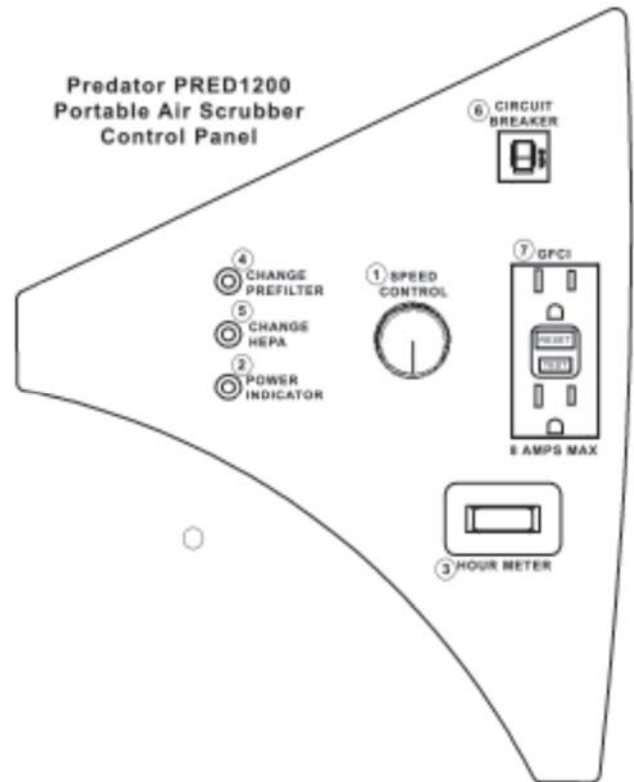

STARTING THE UNIT

1. Check to make sure that the Speed Control Switch is in the “OFF” position. Plug the power cord into a 120 volt AC, 60 Hz, 15 amp supply circuit.
2. Turn Speed Control switch clockwise past the click at the “HIGH” setting to turn power “ON”.
3. Set Speed Control switch to desired setting.

Note: Refer to the chart in this instruction manual entitled PRED1200 SPECIFICATIONS that lists the airflows for the PRED1200.

Note: In the event of a power failure while the unit is running, or loss of power due to any other cause, after a brief delay this unit’s motorized impeller will re-start when power is restored.

TRANSPORTING THE UNIT

The PRED1200 can be transported in the horizontal position. If extremely poor road conditions exist, or excessive shock and vibration are expected, take precautionary measures by padding the unit to provide impact absorption during transport.

⚠ Caution: Always use caution when moving the PRED1200 Portable Air Scrubber inside a building or home. The unit weighs 70 pounds. Older structures with weakened floors or staircases may require special considerations for safe transport.

FOAM INLET PLUG

The PREDATOR® Portable Air Scrubber comes with a foam plug (P/N: PLUG10) that fits into the inlet of the unit. Be sure to remove the foam inlet plug before use and insert it back into the inlet after use. The foam plug keeps any collected contaminants that are caught in the filters or inside the cabinet from escaping the unit when the unit is not in use.

USER SERVICING INSTRUCTIONS

Abatement Technologies’ portable air scrubbers are designed to be low maintenance devices and basic maintenance should be performed as follows:

- Filters should be changed as needed based on the filter change indicator light. Follow the FILTER CHANGE PROCEDURE as described in this manual. Filters can be changed earlier, if desired, to maintain a minimum required flow rate.
- The unit should be cleaned with a damp cloth or a water-based cleaner/sanitizer as needed. Do not use harsh chemicals, solvents, or detergents to clean the unit.

⚠ Warning: Keep electrical components dry as their exposure to liquids poses a safety hazard and can damage components.

FILTER REPLACEMENT

Note: Personnel responsible for changing filters, servicing units or relocating units within the facility are urged to wear the proper personal protective equipment (PPE) and follow safe work practices in accordance with federal, state, provincial, local and employer regulations. Abatement Technologies cannot recommend the type of PPE required as that will need to be determined by safety/risk assessment personnel based on various risk factors, including the type of particulates being captured by the air filtration device and the surrounding environment where the units are being used, transported, or serviced.

Note: Filters being replaced must be disposed of in accordance with federal, state, provincial, local, and facility regulations.

System airflow reduction is generally the result of filter loading, blockage of the unit’s inlet, or use of excessive lengths of flex duct.

The size and concentration of airborne contaminants, temperature and humidity conditions, and duration of use determine how often filters need replacement. If the Pre-filter Filter Change Indicator on the control panel illuminates, this indicates one or more of the following: (1) pre-filter(s) are loaded, (2) the inlet is obstructed, and/or (3) the flex duct, if attached to inlet, is too long or has too many bends. If the HEPA Filter Change Indicator on the control panel illuminates, this indicates one or more of the following: (1) HEPA filter is loaded, (2) the inlet or outlet is obstructed, and/or the flex duct, if attached, is too long or has too many bends.

If using an activated carbon filter, the method of determining when to replace this particular filter is somewhat subjective. As the odor, vapor, and/or gas filtration capacity decreases, the user will begin to sense a slight odor or taste of the contaminant, indicating that the filter should be replaced.

Note: The filters are not reusable, therefore, do not attempt to clean and reuse them.

⚠ Caution: Abatement Technologies PREDATOR® Portable Air Scrubber units are designed to meet or exceed standards for high efficiency air filtration equipment. Use only Abatement Technologies parts, including replacement filters. **Use of non-Abatement Technologies parts and filters voids the product warranty and all performance claims.**

⚠ Warning: To reduce the risk of fire, electrical shock or personal injury, always turn the unit “OFF” and disconnect the power cord from supply receptacle before replacing the HEPA filter and before cleaning or servicing the unit.

Filter Change Indicator

The Filter Change Indicator lights illuminating indicate one or more of the following:

1. Loaded filter(s). Refer to FILTER CHANGE PROCEDURE.
2. Restrictions on air intake. Refer to TROUBLESHOOTING GUIDE.

Filter Change Procedure

The filter change indicator lights located on the control panel will indicate when one or more of the filters need to be changed. This is based on a factory setting and the filters can be changed earlier, if desired, to maintain a minimum air flow requirement.

Note: Since the Primary Filter Change Indicator Light is based on the pressure drop across all of the pre-filters, it cannot indicate specifically which filter needs to be changed. Therefore, when the Filter Change Indicator Light illuminates, the first stage filter should be changed first to see if the light turns off. If the light remains, then the second stage filter should be changed followed by the optional third stage filter.

Changing the First Stage Filter:

1. With the unit operating, turn the latch on the pre-filter access door counterclockwise (approximately ½ turn), and open the door.
2. Remove the first stage filter and replace it with a new one. Be sure to slide the filter all the way into the unit’s cabinet.
3. Close the door and lock it in position by turning the latch clockwise. Make sure the door is flush against the PRED1200 cabinet before closing latch.
4. If the pre-filter change indicator remains “ON” after changing the first stage filter, the second stage filter should be replaced.

Changing the Second and/or Third Stage Filter:

1. Open the pre-filter access door.
2. Remove the pleated filter and replace it with a new one.
Note: If a VAPOR-LOCK® filter is being used, be sure to remove it from its poly bag before installing it in the unit. VAPOR-LOCK® filters are packaged in poly bags to preserve the integrity of the carbon granules.
3. Close the door and lock it in position.

Changing the HEPA Filter:

1. Turn the unit "OFF" and disconnect the power cord from the electrical outlet.
2. Remove the screws that hold the HEPA filter access panel in place and set the panel aside.
3. Remove the wing nuts that secure the HEPA filter retaining bracket in place, slide the bracket off the long filter retaining bolts and remove the HEPA filter.
4. Carefully place a new HEPA filter (P/N: H610C-99) into the cabinet, making sure that it rests on the curved section of the cabinet base, which is just behind the long, lower filter retaining bolt. The foam seal of the filter should be aligned with the exhaust outlet.
5. Place the HEPA filter retaining bracket over the retaining bolts and secure it in place with the wing nuts. Do not over-tighten the wing nuts.
6. Re-attach the HEPA filter access panel and secure it to the cabinet with its screws.

⚠ Warning: Use only Abatement Technologies pre-filters, HEPA filters, and replacement parts. Substitute parts void the warranty, jeopardize worker and environmental safety, and adversely affect engineered performance levels.

COMPONENT REPLACEMENT AND CARE OF THE UNIT

⚠ Warning: To reduce the risk of fire, electrical shock or personal injury, always turn the unit "OFF" and disconnect power cord from supply receptacle before removing the control panel, replacing the HEPA filter and before cleaning or servicing the unit. This unit is equipped with an automatic restart motorized impeller that will restart without warning after a temporary power interruption or recovery from a thermal overload (over-heating) condition. Keep clear of the motorized impeller at all times to reduce the risk of injury.

Occasionally a defective component will cause the unit to operate improperly or not at all. Any electrical component can fail. Refer to the Wiring Diagrams and Wiring Schematics to diagnose the failure of any component. Diagnostics should only be performed by a technician qualified to service electrical equipment.

The unit should be cleaned with a damp cloth or a water-based cleaner/sanitizer. Do not use harsh chemicals, solvents or detergents to clean the unit.

⚠ Warning: Keep electrical components dry as their exposure to liquids poses a safety hazard and can damage components.

PRED1200 SPECIFICATIONS

FEATURE	SPECIFICATIONS
Net weight with filters:	70 lbs.
Shipping weight:	95 lbs.
Unit dimensions:	22" L x 24" W x 42" H
Power supply requirements:	Minimum 120 VAC, 60 Hz, 15 A
Normal operating amps:	3.5 amps or less
Integrated circuit breaker:	12 amps
Motorized impeller:	400 watt motorized impeller with thermal overload protection, auto re-set, 60 Hz, single phase.
Operating flow rate* (with clean filters):	Variable, 300 – 900 CFM
Operational sound level:	62 – 67 dBA on high speed, reading taken at 5'.
Cabinet:	UL94HB flame retardant resin with EPA-Registered microbial inhibitor.
Transportability:	2 each 8" rubber wheels in rear and 2 ea. 360° swivel casters in front.
Foam inlet plug:	Foam plug for sealing inlet to protect against spillage during transit (P/N: PLUG10).
Pre-filter access:	Easy-operating hinged door is secured by rotating latch to protect against filter by-pass.
First stage pre-filter:	1" deep coarse particulate pre-filter (P/N: F621).
Second stage pre-filter:	2" deep pleated particulate pre-filter (P/N: H502).
Optional third stage pre-filter:	2" deep high capacity carbon filter for odors (P/N: VL1002).
HEPA filter:	Tested and certified to an efficiency of 99.97% or higher against 0.3 micron size particles (P/N: H610C-99).
Patent:	U.S. Design Patent No. D572,356

Note: Specifications subject to change without notice.

*Airflow rating estimates are based on factory testing at 120 VAC, 60 Hz with an air straightener and a traverse of readings taken with a computing vane-anemometer. Actual results may vary for various reasons, including motor and blower and HEPA filter tolerances. Factors such as filter loading, reduced voltage to the motor, and inlet and outlet ducting will reduce airflow. Use the ratings as a general guideline only.

TROUBLESHOOTING GUIDE

PROBLEM	POSSIBLE CAUSE	SOLUTION
No response when the power is turned on	Power cord unplugged.	Plug power cord firmly into electrical outlet in wall.
	Defective power cord.	Check all connections and condition of cords. Do not operate with damaged power cord(s).
	Tripped circuit breaker.	Reset breaker for building. Reset 12 amp breaker located on unit.
	Tripped ground fault circuit interrupter or residual current device.	Reset GFCI on control panel or GFCI/RCD at the power source. Note: Unit must be plugged in when resetting GFCI on control panel.
	Thermal overload on the motorized impeller has tripped.	Turn unit "OFF", wait 30 minutes and restart unit.
Circuit breaker on control panel or building "trips".	Overloaded circuit.	Unplug any additional equipment connected to the circuit. Reset circuit breaker.
Filter change indicator is ON".	Loaded filters.	Change in accordance with operating instructions.
	Excessive restrictions.	Reduce bends, length of flex duct, or eliminate restrictions.
	If using a carbon pre-filter, carbon filter has not been removed from polybag.	Remove carbon filter from polybag.

Note: If the unit does not start or malfunctions after carefully following the TROUBLESHOOTING GUIDE, call Abatement Technologies service department at +1 800-634-9091 (U.S.) or +1 905-871-4720 (Canada) for assistance.

CERTIFICATION OF ROOM AIR FILTRATION UNITS



Abatement Technologies PRED1200 air filtration units are independently tested and certified to the relevant safety requirements by TÜV SÜD.

TÜV SÜD is accredited by the U.S Occupational Safety and Health Administration (OSHA) as a Nationally Recognized Testing Laboratory (NRTL).

LIMITED WARRANTY

Abatement Technologies, Inc (ATI) warrants that goods sold to the original user shall be free from defects in material and workmanship for a period of 1 year, except such as are commercially acceptable. This warranty does not include useful filter life. ATI does not warrant that the goods sold are merchantable or fit for any particular purpose. ATI makes no warranties other than as stated in this paragraph. All other warranties, guaranties, or representations, express or implied, by operation of law or otherwise, are expressly disclaimed. **Goods found by ATI to be defective or not to conform to specification shall upon return be replaced or repaired by ATI without any additional charges, or, at ATI's option, ATI may refund the purchase price of such goods. ATI will pay return transportation charges on returned goods not exceeding the transportation charges applicable to shipment from original destination unless the returned goods are free from defect and conform to specifications. Returned goods which are found by ATI to be free from defect and to conform to specifications shall be held for Purchaser's shipping instructions, which instructions Purchaser shall furnish promptly upon request.** ATI's liability shall in no event extend beyond replacement, repair or refund of the purchase price and ATI shall not be liable under any circumstances for special, contingent or consequential damages, nor for loss, damages, or expenses directly or indirectly arising from the use of the goods, including without limitation, warehousing, labor, handling and service charges, die, equipment, or machine breakage, nor for costs, lost profits or loss of good will. The use of substitute, non-ATI parts and/or filters, in any ATI product, voids all warranties and performance claims. The remedies set forth herein are exclusive.

For warranty information and assistance contact Abatement Technologies' Customer Service Department at +1 800-634-9091 (U.S.) or +1 905-871-4720 (Canada).

HEPA CERTIFICATION

Abatement Technologies' PRED1200 high-efficiency air filtration units are originally equipped with true HEPA (High Efficiency Particulate Air) filters designed to maximize the performance of the equipment, and to meet the following industry standards:

Institute of Environment Sciences and Technology
IEST-RP-CC001 (Type A HEPA and ULPA Filters)
IEST-RP-CC021 (Testing HEPA and ULPA Filter Media)

Underwriters Laboratories
UL900

100% Efficiency Tested

Abatement Technologies HEPA filters are individually tested and certified to ensure that the completed filter provides an overall minimum efficiency of 99.97% when challenged by a thermally generated test aerosol, 0.3-microns in size, in accordance with IEST-RP-CC034.

PRED1200 DIAGRAMS

Predator 1200 Control Panel Wiring Diagram

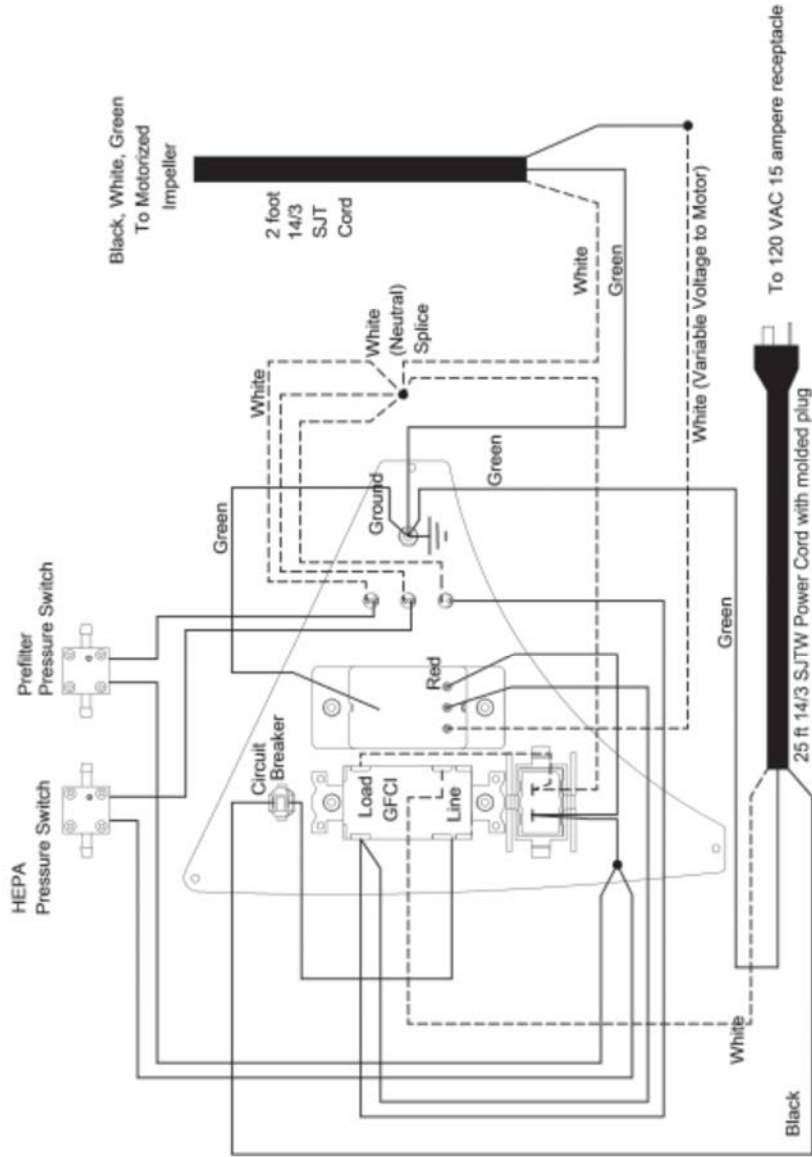

rev.C

Predator 1200 Motorized Impeller Wiring Diagram

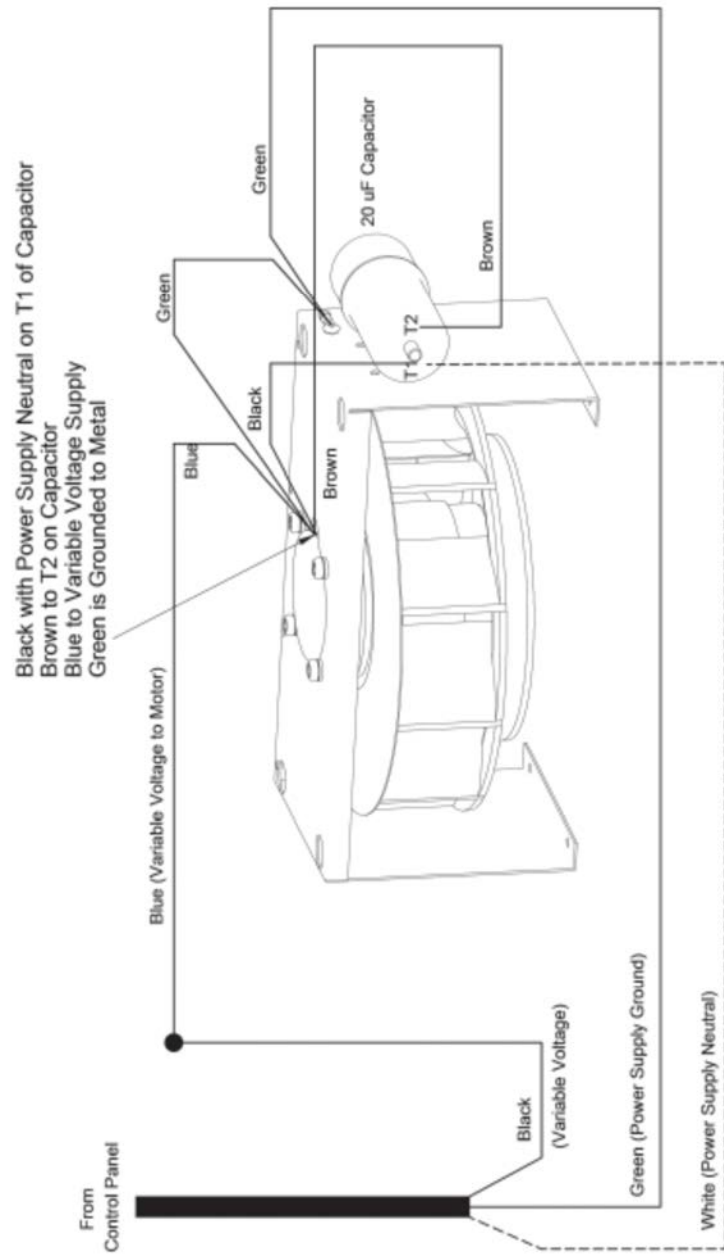

rev. C

Predator 1200 Wiring Schematic

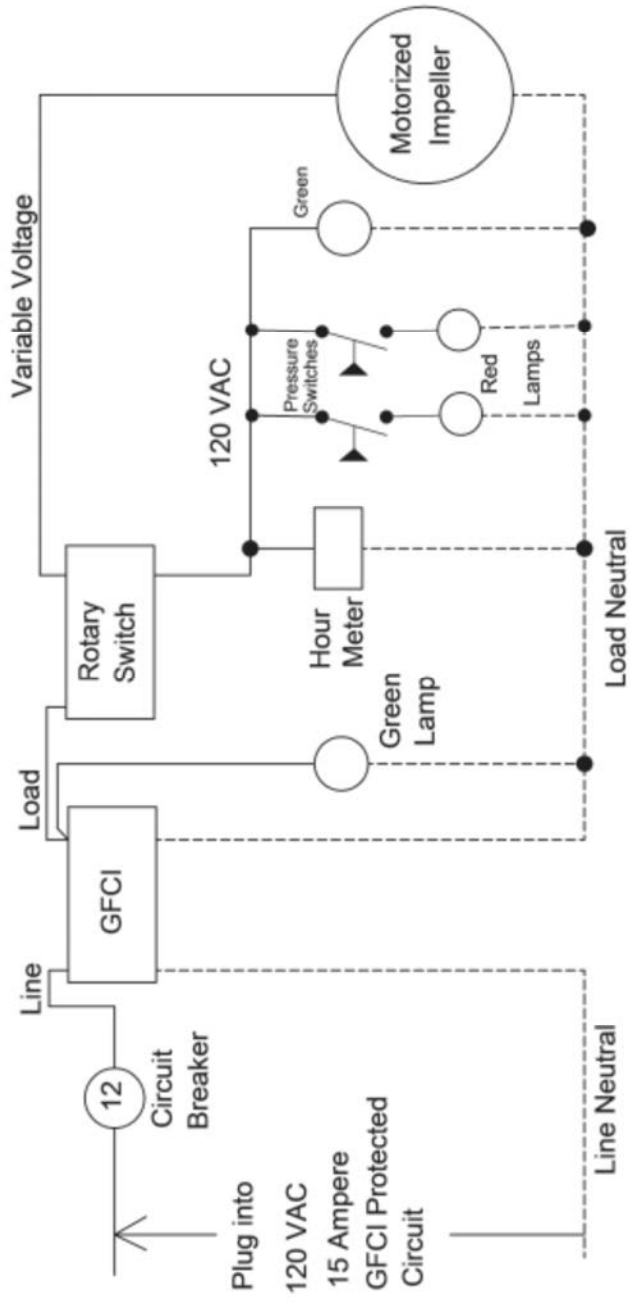

rev. C

PRED1200

MECHANICAL VARIABLE SPEED MOTOR
CONTROLLER STARTING WITH S/N 08Q316620

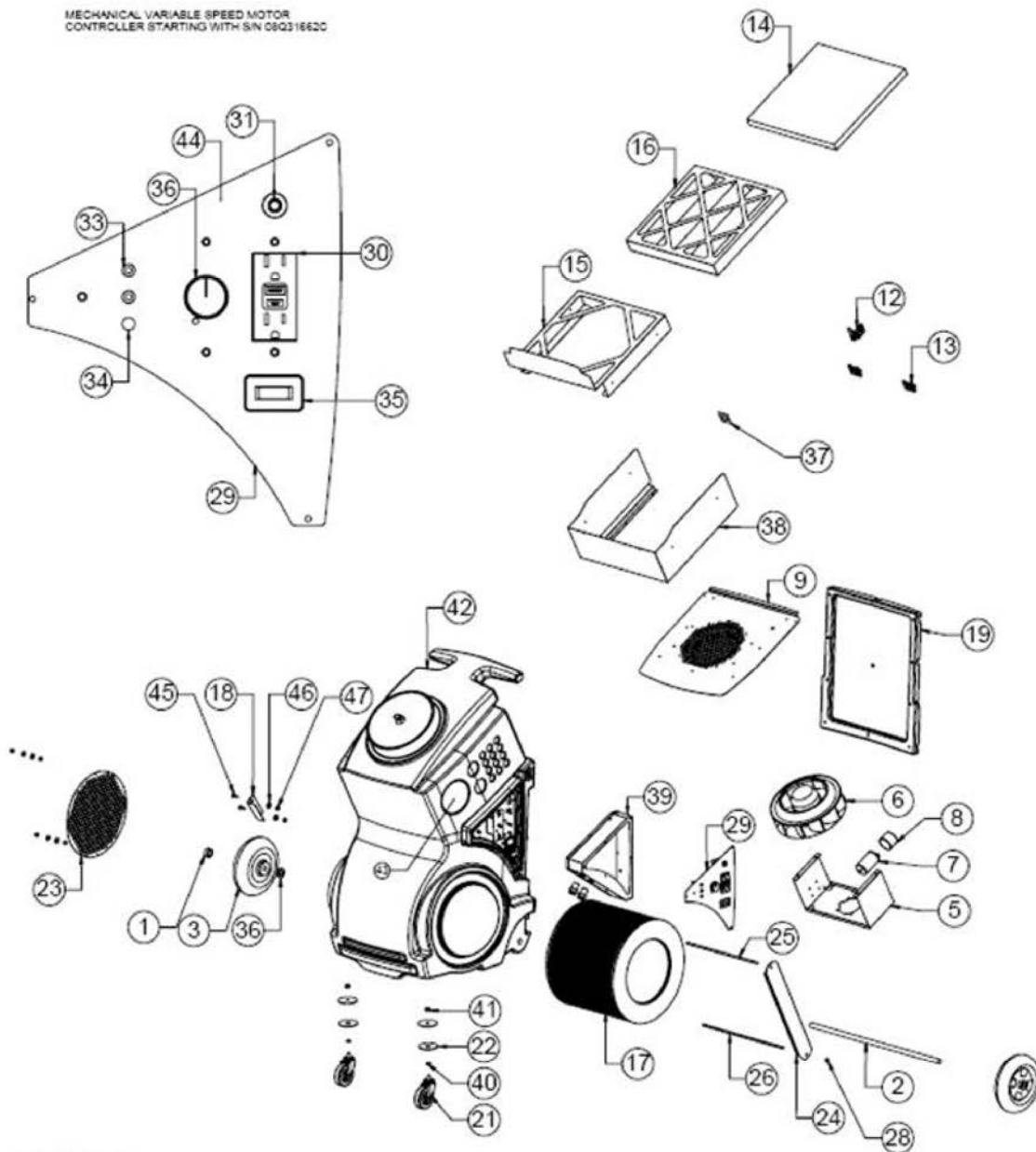

PRED1200EVJ
STARTING SERIAL # I51016405987
04/26/2017

PRED1200

ITEM	PART No.	DESCRIPTION	QTY.
1	HARDWARE65	AXLE LOCKING BUSHING	2
2	1367	AXLE	1
3	CASTER17	8" NON-MARK WHEEL	2
4	BLWRASY17	BLOWER ASSEMBLY	1
5	1357	IMPELLER MOUNTING BRACKET	1
6	BLOWER34	250 MOTORIZED IMPELLER	1
7	ELE116	CAPACITOR	1
8	ELE133	CAPACITOR BOOT CAP	1
9	VENTURI15	250 VENTURI	1
10	1368	VENTURI PLATE	1
11	2384	PREFILTER DOOR	1
12	LATCH12	COMPRESSION DOOR LATCH	1
13	HARDWRE153	DOOR HINGE	2
14	F621	PREFILTER	1
15	1359	PREFILTER SUPPORT	1
16	H502	PLEATED FILTER	1
17	H610C-99	HEPA FILTER	1
18	2385	HEPA FILTER DOOR	1
19	ELE12	STRAIN RELIEF	1
20	CORD15	CORD WITH PLUG	1
21	CASTER02	CASTER	2
22	WASHER33	FLAT WASHER	4
23	1377	OUTLET GRILL	1
24	1356	HEPA HOLD DOWN BRACKET	1
25	1362	THREADED ROD TOP	1

ITEM	PART No.	DESCRIPTION	QTY.
26	1358	THREADED ROD BOTTOM	1
27	NUT32	1/4"-20 WING NUT	2
28	WASHER21	1/4"x3/4" WASHER	2
29	CTRLPNL46	CONTROL PANEL ASSMEMBLY	1
30	ELE71	15 AMP GFCI RECEPTACLE	1
31	ELE152	12 AMP CIRCUIT BREAKER	1
32	LAMP23	RED SOLICO LAMP	2
33	LAMP24	GREEN SOLICO LAMP	1
34	ELE103	HOUR METER	1
35	H5016	INTRUMENT KNOB	1
36	ELE21	HEYCO NUT	1
37	WASHER16	LEXAN WASHER	2
38	WASHER29	SQUARE WASHER	2
39	1368	PREFILTER BOX	1
40	1495	CONTROL BOX ENCLOSURE	1
41	WASHER15	3/8" SPLIT WASHER	2
42	NUT13	3/8"-16 HEX NUT	2
43	2383	MAIN BODY	1
44	LABEL109	ROUND SIDE LOGO LABEL	1
45	1493	CONTROL PANEL PLATE	1
46	LABEL97	CONTROL PANEL OVERLAY	1
47	SCREW64	1/4-20x1" CARRIAGE BOLT	2
48	WASHER01	3/8" SAE WASHER	2
49	WASHER27	1/4" ID X 5/8" OD FLAT WASHER	2
50	NUT10	1/4"-20 KEPS NUT	2

NOT SHOWN IN EXPLODED VIEW

	WM211751.4	PRESSURE SWITCH	1
	WM211773.0	PRESSURE SWITH	1
	1493	CONTROL PANEL PLATE	1
	H5015	VARIABLE SPEED CONTROL	1

PRED1200EVJ

STARTING SERIAL # : I51016405987

04/26/2017