

**ALKALINE-MANGANESE DIOXIDE BATTERY**

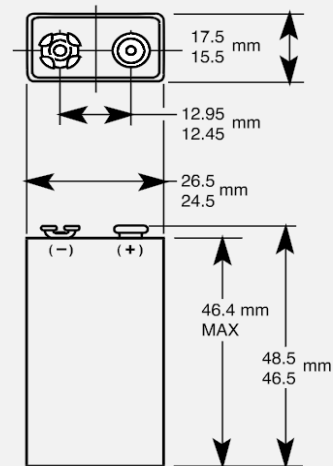

Size: 9V (6LR61) PX1604



Dimensions shown are IEC standards

**KEY FEATURES**

- Reliable Performance
- Excellent resistance to corrosion
- Designed to meet all major quality, safety and environmental standards:
  - Safety: IEC 60086-5
  - ANSI C 18.1M, Part-2
  - EU Battery Directive
  - Quality: ISO 14001 and 9001, Duracell World Class Continuous Improvement Program

**TYPICAL APPLICATIONS**

- Door Locks
- Air Fresheners
- Medical Devices
- Radios

**ELECTRICAL CHARACTERISTICS**

- Nominal capacity (2 mA Cont., 5V cut-off) 726 mAh
- Typical Voltage (at + 20 °C) 9 V
- AC Impedance @ 1kHz 1,692 mΩ

**PHYSICAL CHARACTERISTICS**

- Typical weight 48.5 g (1.6 oz)
- Typical volume 22.8 cm<sup>3</sup> (1.4 in<sup>3</sup>)
- Terminals Miniature snap

**OPERATING & STORAGE CONDITIONS**

- Operating temperature range -20°C to 54°C  
(-4°F to 130°F)
- Recommended Storage (storage area should be clean, cool, dry and ventilated) 5°C to 30°C  
(41°F to 86°F)

TYPICAL PERFORMANCE

Constant Current

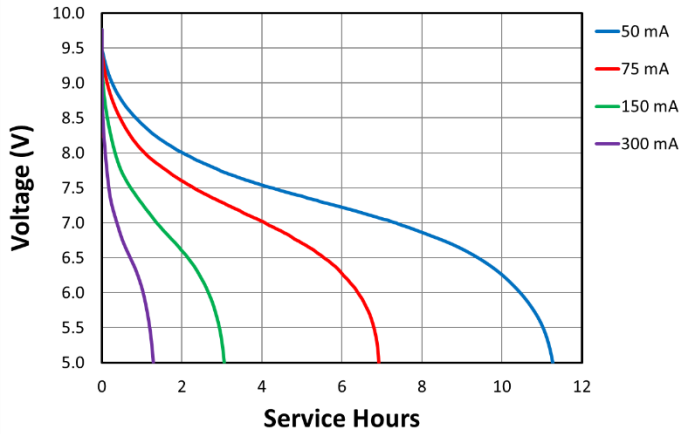

Constant Current

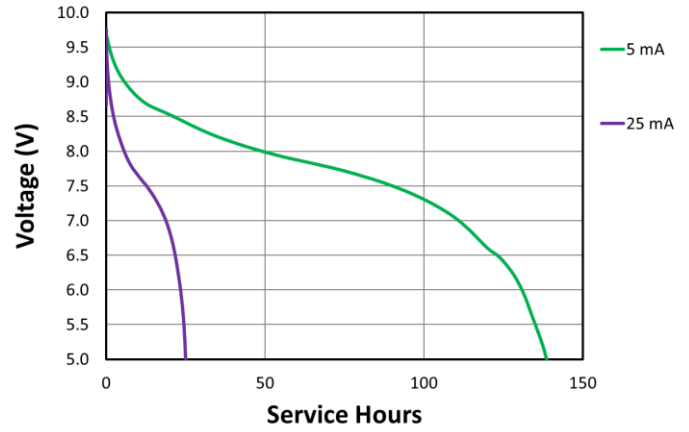

Constant Resistance

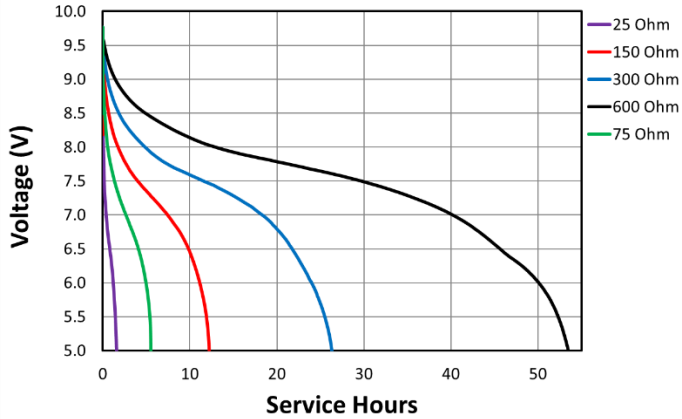

Constant Power

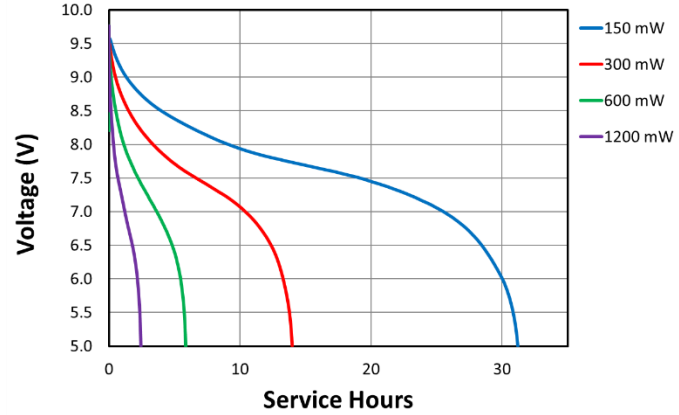

Constant Current - 75mA

